

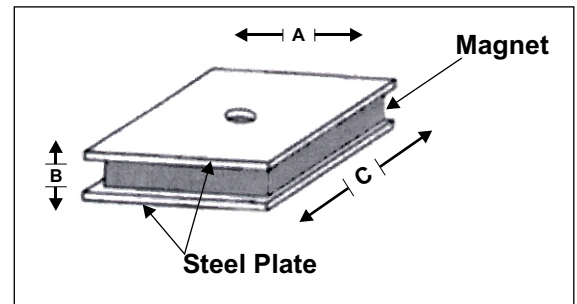

ENEFLUX ARMTEK MAGNETICS, INC.
magnets for industry



Sandwich Assembly Magnets



SANDWICH ASSEMBLIES				
EAM Part No.	Length	Width	Thickness	Lift Strength
SP-0612	1.060	0.844	0.313	10
SP-0613	1.060	0.844	0.313	16
SP-0614	1.060	0.844	0.563	20
SP-0615	2.094	0.844	0.313	22
SP-0616	3.060	0.844	0.313	22
SP-0617	2.125	0.625	1.060	50
SP-0618	2.125	0.625	1.000	50

700 Hicksville Road • ENECON Center Suite 110 • Bethpage, New York 11714
Toll Free: 877-ENEFLUX • Phone: 516.576.3434 • Fax: 516.349.5522
Website: www.eamagnetics.com • Email: info@eamagnetics.com

Standard Round Base Assembly Magnets

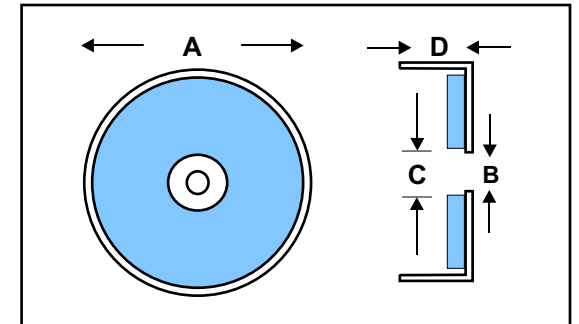

ROUND BASE MAGNETIC ASSEMBLIES

EAM Part No.	Overall Diameter (A)	Cup Hole Size (B)	Magnet Hole Size (C)	Height (D)	Lift Strength (Lbs.)	Base Finish
SP-0028	4.900"	0.500"	1.750"	0.500"	210	Chrome
SP-0270	3.200"	0.375"	1.188"	0.438"	110	Vinyl
SP-0175	3.200"	0.375"	1.188"	0.438"	110	Nickel
SP-0017	3.200"	0.280"	1.188"	0.438"	110	Nickel
SP-0265	2.875"	0.270"	1.000"	0.365"	85	Chrome
SP-0014	2.625"	0.280"	1.000"	0.375"	80	Nickel
SP-0360	2.625"	0.280"	1.000"	0.375"	80	Vinyl
SP-0013	2.030"	0.187"	0.844"	0.313"	35	Nickel
SP-0002	1.400"	0.187"	0.375"	0.280"	15	Nickel
SP-0396	1.205"	0.125"	0.156"	0.188"	5	Nickel

Channel Assemblies

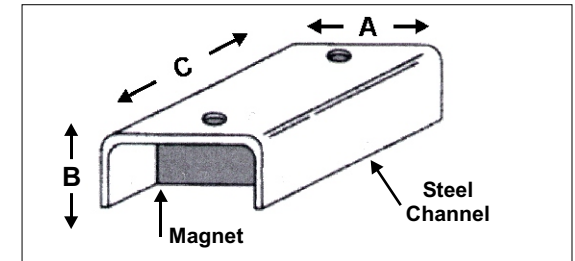

CHANNEL ASSEMBLIES

EAM Part No.	Width (A)	Height (B)	Length (C)	Mounting	Lift Strength (lbs.)	Finish
SP-0600	0.875	0.250	1.00	0.125 center hi	2	Nickel
SP-0601	0.625	0.190	12.00	0.150 side holes	10	Zinc
SP-0030	1.330	0.260	1.50	loop	10	Nickel
SP-0602	0.950	0.313	2.00	none	14	Nickel
SP-0038	0.950	0.313	2.00	0.170 side holes	14	Nickel
SP-0603	0.950	0.313	2.00	0.170 side holes	14	Black
SP-0604	0.950	0.313	2.00	knob	14	Nickel
SP-0605	0.875	0.250	1.00	0.125 center hi	15	Nickel
SP-0606	0.906	0.250	3.00	threaded nut	22	Chrome
SP-0607	0.906	0.250	3.00	none	22	Nickel
SP-0608	0.916	0.400	2.70	0.187 side holes	25	Zinc
SP-0609	0.916	0.400	2.70	loop	25	Zinc
SP-0519	1.500	0.460	3.00	0.260 slots	60	Zinc
SP-0356	1.050	0.455	8.00	0.435 slots	60	Zinc
SP-0610	1.505	0.455	8.00	0.435 slots	30	Black Poly
SP-0245	1.500	0.475	6.00	0.250 side holes	100	Zinc
SP-0611	1.720	0.620	12.00	0.250 side holes	150	Zinc